



**RAK-ECOFIX**

**RAK**  
CERAMICS

**ROOM FOR  
IMAGINATION**

**RAK**  
CERAMICS

## ICONS

### TECHNICAL INFORMATION

Informazioni Tecniche  
Informations Techniques  
Technische Informationen

#### APPLICATION

Applicazione | Application | Anwendung

#### DETAILS

Dettagli | Détails | Details



**FOR BACK TO WALL WC**  
Per WC a filo muro  
Pour WC posé au sol  
Für Rückwandmontage WC



**FOR WALL HUNG WC**  
Per WC sospeso  
Pour WC contre le mur  
Für Wandhängendes WC



**FOR BACK TO WALL BIDET**  
Per bidet a filo muro  
Pour bidet contre le mur  
Für Rückwandmontage Bidet



**FOR WALL HUNG BIDET**  
Per bidet sospeso  
Pour bidet suspendu au mur  
Für Wandhängendes Bidet



**FOR URINAL**  
Per orinatoio  
Pour urinoirs  
Für Urinal



**12 CM THICKNESS**  
Spessore 12 CM  
Épaisseur 12 CM  
12 CM Dicke



**8 CM THICKNESS**  
Spessore 8 CM  
Épaisseur 8 CM  
8 CM Dicke



**82 CM HEIGHT**  
Altezza 82 CM  
Hauteur 82 CM  
82 CM Höhe



**WATER SUPPLY**  
Allaccio Idrico  
Arrivée D'eau  
Wasserzulauf



**FIXATIONS INCLUDED**  
Fissaggi inclusi  
Fixations inclus  
Befestigungen enthalten



**WALL ANCHORING INCLUDED**  
Ancoraggio a parete incluso  
Anclage mural inclus  
Enthaltene Wandverankerung



**6L DUAL FLUSHING**  
Doppio scarico 6L  
Double drain 6L  
6L Doppelter Abfluss



**COMPATIBLE WITH 4.5L DUAL FLUSHING**  
Compatibile con doppio scarico 4.5L  
Compatible avec double drain 4.5L  
Kompatibel mit 4.5L Doppelter Abfluss



**3L DUAL FLUSHING**  
Doppio scarico 3L  
Double drain 3L  
3L Doppelter Abfluss



**MOTION SENSOR**  
Sensore di movimento  
Capteur de mouvement  
Bewegungssensor



**4x AA Battery**  
Batteria 4x AA  
Batterie 4x AA  
4x AA Batterie

## RAK-ECOFIX LIMITLESS TECHNOLOGY FOR LIMITLESS IMAGINATION

RAK-Ecofix Flushing systems by RAK Ceramics are the ideal solution for all types of hydro-sanitary systems. Invisible built-in flushing systems combine functionality and aesthetics, saving space in every bathroom. The new and elegant push plates integrate perfectly with any style and design of dual flush systems to reduce water consumption.

All systems perfectly integrate with all of RAK Ceramics Wall Hung & BTW WCS and bidets and fit perfectly into any home environment or contract specification.

Technology, innovation and water saving features make RAK-Ecofix the perfect choice for your bathroom, whatever you have imagined.



I sistemi di risciacquo RAK-Ecofix by RAK Ceramics sono la soluzione ideale per tutte le tipologie di impianto idrosanitario. Le invisibili cassette di risciacquo da incasso uniscono funzionalità ed estetica, con un notevole risparmio di spazio in ogni tipo di bagno. Le nuove ed eleganti placche di comando si integrano perfettamente con qualunque stile e design ed i sistemi dual flush riducono il consumo di acqua. Tutti i sistemi sono perfettamente integrati con la ampia gamma di sanitari sospesi o a filo muro RAK Ceramics e si adattano alla perfezione ad ogni ambiente domestico o alle esigenze dei grandi progetti. Tecnologia, innovazione e attenzione al risparmio idrico fanno di RAK-Ecofix la scelta ideale per il tuo bagno, in qualunque modo tu lo abbia immaginato.



Les systèmes de chasse d'eau RAK-Ecofix de RAK Ceramics offrent la solution idéale pour tout type d'objets hydro-sanitaires. Les invisibles réservoirs de chasse d'eau encastrés unissent la fonctionnalité et l'esthétique avec une économie d'espace considérable dans tout type de salle de bains. Les plaques-poussoirs s'intègrent à merveille dans tout style et tout design, et les systèmes de chasse d'eau de cabinet duals réduisent la consommation d'eau. Tous les systèmes se relient parfaitement avec le grand choix d'objets sanitaires posés ou suspendus, et s'adaptent à merveille à toute situation constructive ainsi qu'aux exigences de grands projets. La technologie, l'innovation et l'attention pour l'économie d'eau font de RAK-Ecofix le choix idéal pour votre salle de bains, telle que vous vous l'imaginez.



Die Spülsysteme RAK-Ecofix von RAK Ceramics sind die ideale Lösung für alle Arten hydrosanitärer Anlagen. Die unsichtbaren eingebauten Spülkästen vereinen Funktionalität und Ästhetik mit einer beträchtlichen Raumersparnis in jeder Art von Bad. Die Spültasten integrieren sich hervorragend in jeden Stil und in jedes Design, und die dualen Klosettspülsysteme reduzieren den Wasserverbrauch. Alle Systeme verbinden sich perfekt mit der breiten Auswahl an stehenden oder hängenden sanitären Gegenständen, und passen sich hervorragend jeder häuslichen Umgebung sowie den Anforderungen großer Projekte an. Technologie, Innovation und das Interesse an einer Wasserersparnis machen RAK-Ecofix zur idealen Wahl für Ihr Bad, wie Sie es sich auch immer vorstellen.

In printing, the colour of the products may differ slightly from the actual product. Pictures are only for reference only.

Nella stampa, il colore dei prodotti può differire leggermente rispetto al prodotto reale. Le immagini sono solo per riferimento.  
Dans l'impression, la couleur des produits peut différer légèrement du produit réel. Les images sont uniquement à titre indicatif.  
Beim Drucken kann die Farbe der Produkte geringfügig vom tatsächlichen Produkt abweichen. Bilder sind nur als Referenz.

## FIND YOUR INTEGRATED SOLUTION

The bathroom is a style choice, but clean lines and harmony of the elements, are the result of a complete system of integrated technological solutions. Hidden fixing systems, designer plates and water-saving flush technology. Make your choice, RAK Ceramics guarantees.



## SCOPRI LA TUA SOLUZIONE INTEGRATA

Il bagno è una scelta di stile, ma linee pulite ed armonia degli elementi, sono solo il risultato di un sistema completo di soluzioni tecnologiche integrate. Sistemi di fissaggio nascosto, placche di design, risciacquo a risparmio idrico. Fai la tua scelta, garantisce RAK Ceramics.

## DÉCOUVREZ VOTRE SOLUTION INTÉGRANTE

La salle de bains est, certes, un choix stylistique, mais les lignes claires et l'harmonie des éléments sont uniquement le résultat d'un système complet de solutions technologiques intégrantes. Systèmes de fixation invisibles, plaques-poussoirs de design, chasse d'eau avec économie d'eau. Faites votre choix, RAK Ceramics garantit.

## ENTDECKEN SIE IHR GANZHEITLICHE LÖSUNG

Das Bad ist eine stilistische Wahl, doch klare Linien und Harmonie der Elemente sind einzig das Ergebnis eines kompletten Systems an ganzheitlichen technologischen Lösungen. Unsichtbare Befestigungssysteme, Designtasten, Spülung mit Wasserersparnis. Treffen Sie Ihre Wahl, RAK Ceramics garantiert.

## INDEX

PUSH PLATES | 08

CONCEALED CISTERNS | 12

CABINET CISTERNS | 22

FURNITURE CISTERNS & UNI-FRAME | 26

URINAL FLUSH SENSORS | 28



**PUSH PLATES**  
 PLACCHE DI COMANDO  
 PLAQUES-POUSSOIRS  
 SPÜLTASTEN



**WHITE**

Flush technology: Dual flush  
 Dimensions: 236x152x12 mm

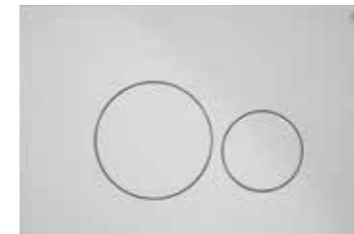

**Code: F5RAKPPL003**  
 ABS  
 White

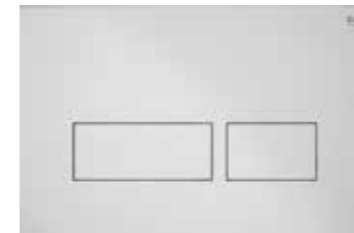

**Code: F5RAKPPL006**  
 ABS  
 White



**Code: FS04RAKWHRO8C**  
 ABS  
 White-Chrome-White

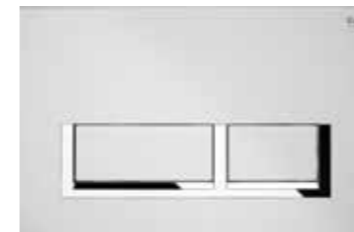

**Code: FS04RAKWHRE8C**  
 ABS  
 White-Chrome-White

**CHROME**

Flush technology: Dual flush  
 Dimensions: 236x152x12 mm



**Code: F5RAKPPL004**  
 ABS  
 Chrome



**Code: F5RAKPPL007**  
 ABS  
 Chrome



**Code: FS04RAKCPB8C**  
 ABS  
 Chrome-Matt chrome -Chrome



**Code: F5RAKPPL002**  
 ABS  
 Chrome-Matt chrome -Chrome

**MATT CHROME**

Flush technology: Dual flush  
 Dimensions: 236x152x12 mm

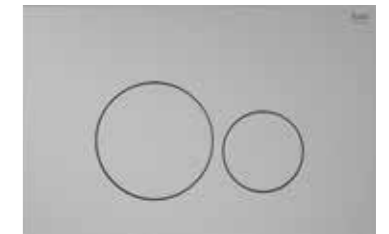

**Code: F5RAKPPL005**  
 ABS  
 Matt chrome

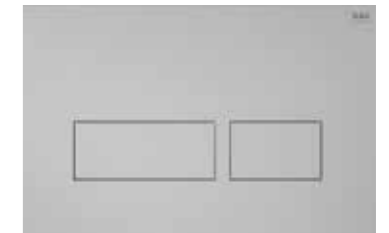

**Code: F5RAKPPL008**  
 ABS  
 Matt chrome



**Code: F5RAKPPL001**  
 ABS  
 Chrome-Matt chrome -Chrome

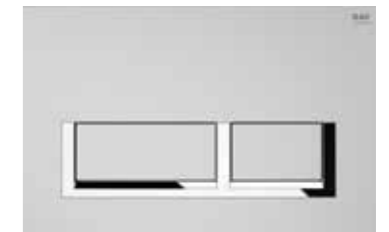

**Code: FS04RAKCPM8C**  
 ABS  
 Chrome-Matt chrome -Chrome

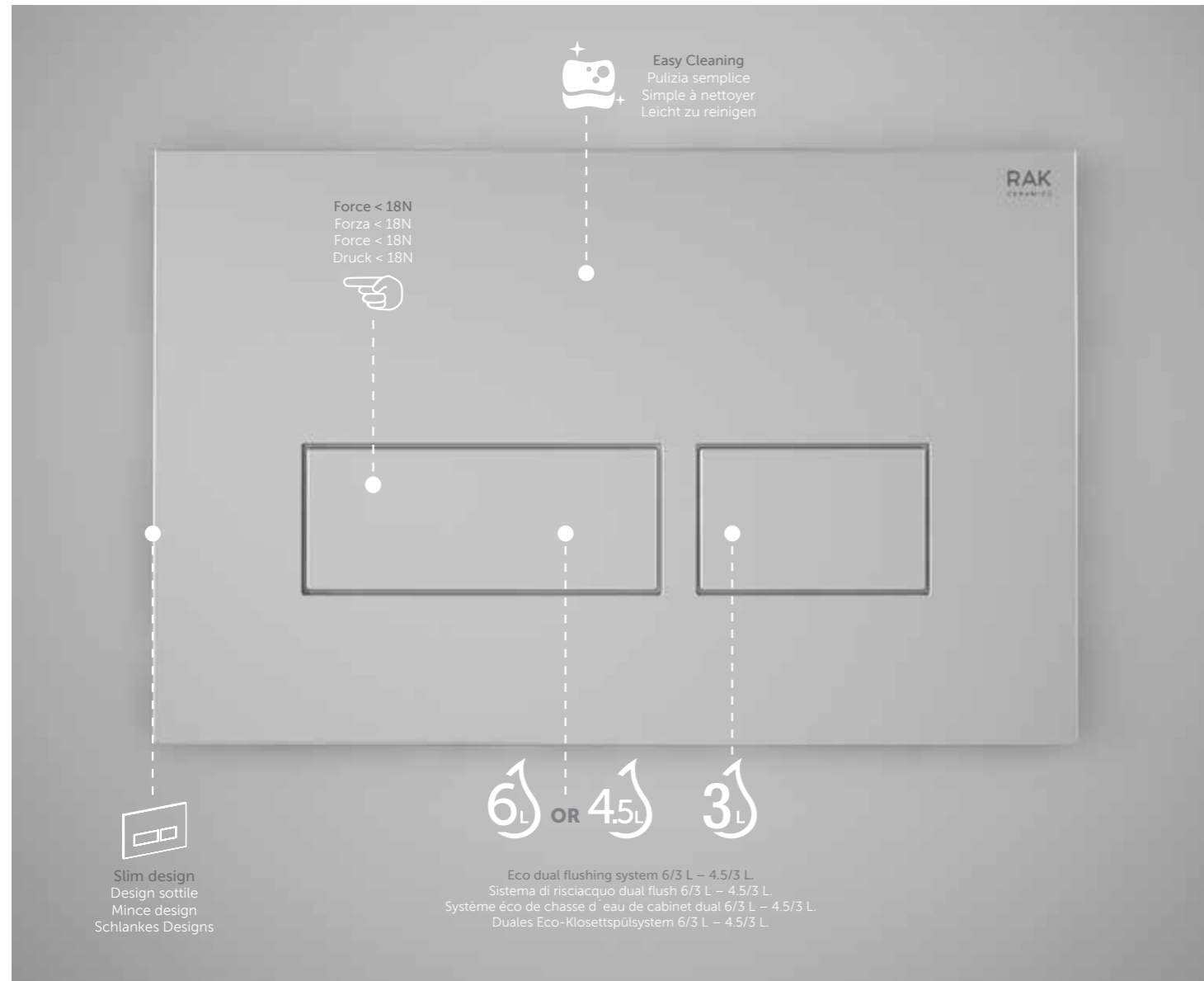

RAK-Ecofix not only offers limitless installation possibilities, but a flat designed range of push plates in 3 elegant finishes and 2 different designs. The push plate is the only visible part of the concealed cistern and is built for the water saving dual system flush in volumes 6-3 liters or 4.5-3 liters. Another possibility to move functionality and style into your bathroom.

Rak-Ecofix non offre solamente infinite possibilità di installazione, ma una gamma di placche di comando in 3 eleganti finiture e 2 differenti design. La placca di comando è l'unica parte visibile del sistema di risciacquo da incasso ed è progettata per attivare il risciacquo a risparmio idrico Dual System da 6/3 litri, o 4.5/3 litri. Stile e funzionalità convivono perfettamente per dare il meglio al tuo bagno.

Au-delà d'une infinité de possibilités d'installation, RAK-Ecofix offre également un grand choix de plaques-poussoirs en 3 finitures élégantes et 2 différents designs. La plaque-poussoir est la seule partie visible du réservoir de chasse d'eau encastré, et est construite pour les systèmes de chasse d'eau de cabinet duals, à l'économie d'eau, pour 6-3 litres ou 4.5-3 litres. Une autre possibilité de conférer à votre salle de bains de la fonctionnalité et du style.

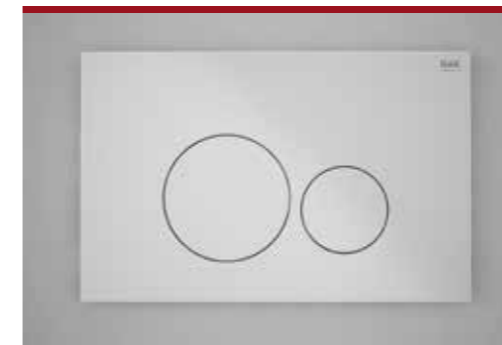

RAK-Ecofix bietet nicht nur unendlich viele Installationsmöglichkeiten, sondern auch eine große Auswahl an Spültasten in 3 eleganten Ausarbeitungen und 2 verschiedenen Designs. Die Spültaste ist der einzige sichtbare Teil des eingebauten Spülkastens, und ist für wassersparende duale Klosettspülsysteme für 6-3 Liter oder 4.5-3 Liter konstruiert. Eine weitere Möglichkeit, Funktionalität und Stil in Ihr Badezimmer zu bringen.  
2 Designs

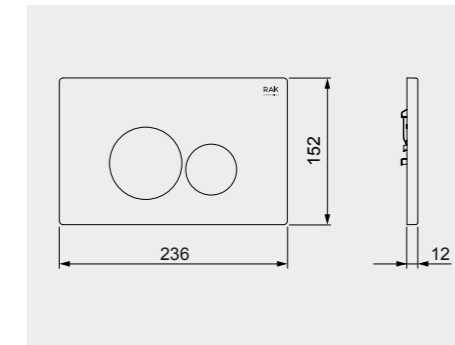

**ROUND**  
Rotondo | Rond | Rund

new  
novità  
nouveau  
neu





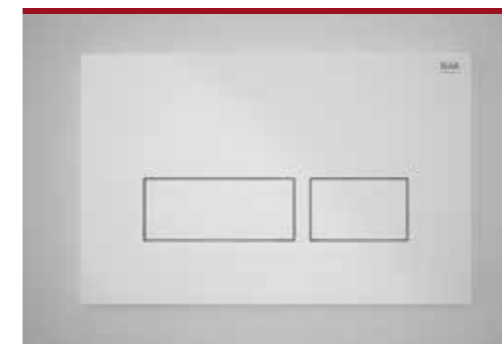

-  White  
Bianca  
Blanc  
Weiß **FSRAKPPL003**
-  Chrome  
Cromo  
Chrome  
Chrom **FSRAKPPL004**
-  Matt Chrome  
Cromo Opaco  
Mat Chrome  
Matt Verchromt **FSRAKPPL005**

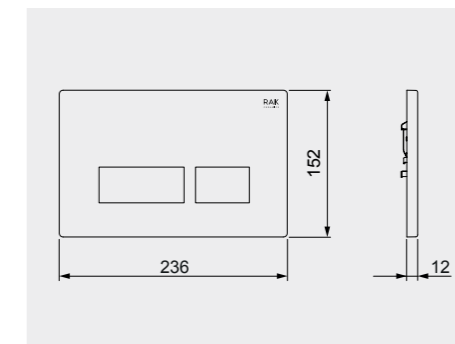

**RECTANGULAR**  
Rettangolo | Rectangulaire | Rechteckig

new  
novità  
nouveau  
neu





-  White  
Bianca  
Blanc  
Weiß **FSRAKPPL006**
-  Chrome  
Cromo  
Chrome  
Chrom **FSRAKPPL007**
-  Matt Chrome  
Cromo Opaco  
Mat Chrome  
Matt Verchromt **FSRAKPPL008**

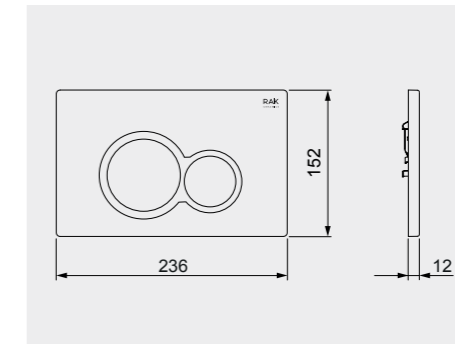

**ROUND**  
Rotondo | Rond | Rund



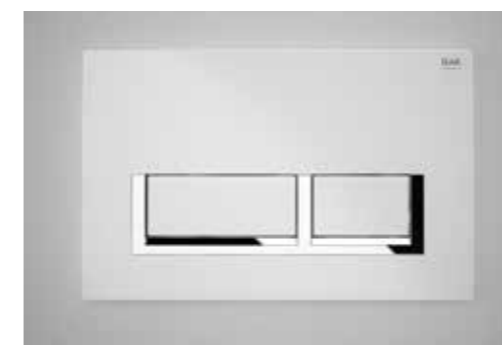

-  White  
Bianca  
Blanc  
Weiß **FS04RAKWHRO8C**
-  Chrome  
Cromo  
Chrome  
Chrom **FS04RAKCPB8C**
-  Matt Chrome  
Cromo Opaco  
Mat Chrome  
Matt Verchromt **FSRAKPPL001**

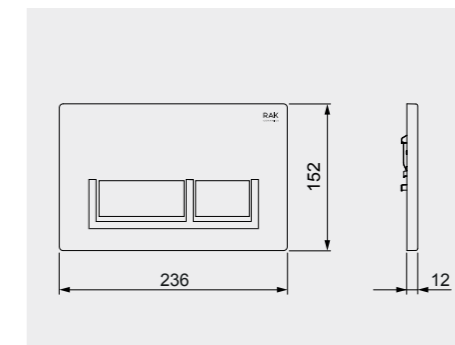

**RECTANGULAR**  
Rettangolo | Rectangulaire | Rechteckig



-  White  
Bianca  
Blanc  
Weiß **FS04RAKWHRE8C**
-  Chrome  
Cromo  
Chrome  
Chrom **FSRAKPPL002**
-  Matt Chrome  
Cromo Opaco  
Mat Chrome  
Matt Verchromt **FS04RAKCPM8C**

**CONCEALED CISTERNS**  
 SISTEMI DI RISCIACQUO DA INCASSO  
 RÉSERVOIRS DE CHASSE D'EAU ENCASTRÉ  
 SEINGEBAUTE SPÜLKÄSTEN



Available in a wide range of dimensions and suitable for any construction situation  
 Connecting to the water grid is simple and fast, without the need for tools or connection accessories.  
 Equipped with top silent fill valve. Easy tool free maintenance at any time through a service opening .

Disponibile in un'ampia gamma di dimensioni e adattabile ad ogni tipo di costruzione. Il collegamento all'impianto idrico è semplice e veloce, senza alcun bisogno di strumenti o accessori. Dotato di valvola di riempimento silenziosa. Facile da ispezionare in caso di manutenzione grazie ad una apertura di servizio.

Disponible en un grand choix de tailles, et approprié à toute situation constructive. Se connecte facilement et rapidement au système de canalisation, sans outils ou éléments de connexion. Doté d'une valve à remplir très silencieuse. Grâce à la niche, toujours accessible pour des travaux de maintenance.

Verfügbar in einer großen Auswahl an Größen und für jede bauliche Situation geeignet. Einfach und schnell an das Abwassersystem anschließbar, ohne Werkzeuge oder Verbindungsstücke. Mit einem sehr leisen Füllventil ausgestattet. Dank der Aussparung, jederzeit frei zugänglich für Wartungsarbeiten.



**BEAUTIFUL DESIGN**  
 LINEA DI DESIGN  
 DESIGN MERVEILLEUX  
 WUNDERSCHÖNES DESIGN

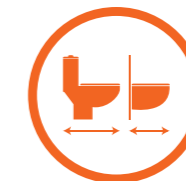

**OPENING SPACE**  
 MAGGIORE SPAZIO  
 PLUS D'ESPACE  
 MEHR PLATZ



**WITHSTANDING HEAVY LOAD**  
 RESISTENTE AL CARICO PESANTE  
 CHARGEMENT MAXIMAL DE 400 KG  
 MAXIMALE TRAGLAST 400 KG



**EASY TO CLEAN**  
 FACILE DA PULIRE  
 FACILE À NETTOYER  
 EINFACH ZUM REINIGEN



**TOP QUALITY**  
 MASSIMA QUALITÀ  
 QUALITÉ EXCELLENTE  
 TOPP QUALITÄT



**WATER SAVING**  
 RISPARMIO DI ACQUA  
 ÉCONOMIE D'EAU  
 WASSERSPAREND

## SOLID WALL INSTALLATION

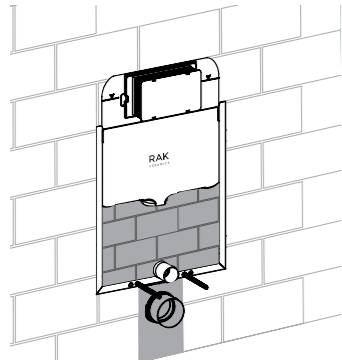

The concealed cistern can be easily fastened in front of or inside a solid wall and then brick lined.

La cassetta nascosta può essere facilmente incassata davanti o dentro a una parete di mattoni e successivamente foderata di mattoni / Le réservoir de chasse d'eau encastré peut être facilement fixé devant ou dans un mur solide, et ensuite crépi / Der eingebaute Spülkasten kann ganz einfach vor oder in einer soliden Wand fixiert, und dann verrohrt.

## DRYWALL INSTALLATION

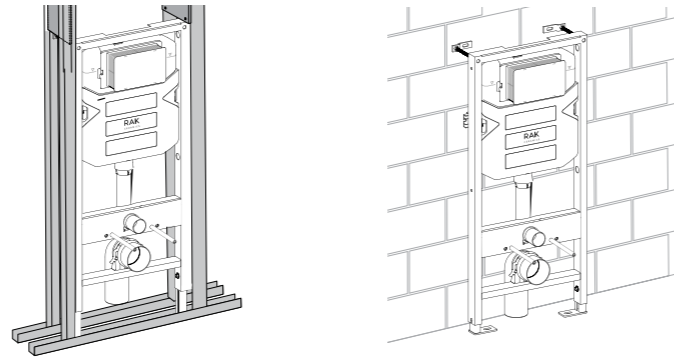

With a drywall system it is possible to create complete room-height prewalls or partitions.

E' possibile creare partizioni e pareti a tutta altezza con il sistema di scarico per muri in cartongesso / Avec un système de placoplâtre, il est possible de construire des doublages complets, à hauteur d'étage ou des cloisons / Mit einem Trockenwandssystem ist es möglich, komplette raumhohe Vorsatzschalen oder Trennwände zu schaffen.

RAK-Ecofix installation elements are suitable for solid constructions and for all drywall construction situations. / Gli elementi RAK-Ecofix sono adatti alle situazioni costruttive in mattoni e a tutte le situazioni costruttive in cartongesso. / Les éléments encastrés de RAK-Ecofix sont appropriés aux constructions solides et à toutes les constructions en placoplâtre. / Einbauelemente von RAK-Ecofix eignen sich für solide Konstruktionen und für alle Trockenbaukonstruktionen.

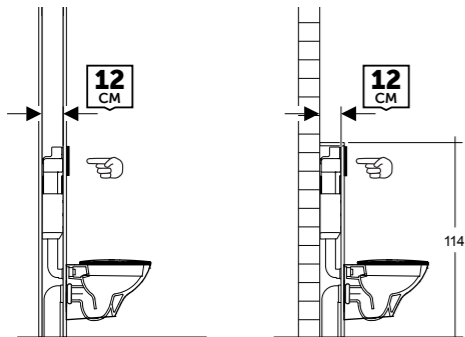

### 12 cm wall-thickness

Pareti da 12 cm / 12 cm d'épaisseur de mur / 12 cm Wanddicke

In the wall or in front of it, with flushing actuation from the front

All'interno del muro o in appoggio, con placca sul fronte.

Dans ou devant le mur, avec commande de chasse d'eau de devant.

In der Wand oder davor, mit Spülbetätigung von vorne.

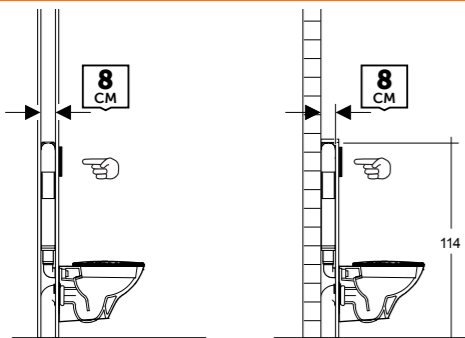

### 8 cm wall-thickness

Pareti da 8 cm / 8 cm d'épaisseur de mur / 8 cm Wanddicke

For thin walls or for space-saving installations, with flushing actuation from the front.

Per installazioni speciali salvaspazio o pareti sottili, con placca sul fronte.

Pour les murs minces ou les constructions qui économisent l'espace, avec une commande de chasse d'eau de devant.

Für dünne Wände oder platzsparende Konstruktionen, mit einer Spülbetätigung von vorne.

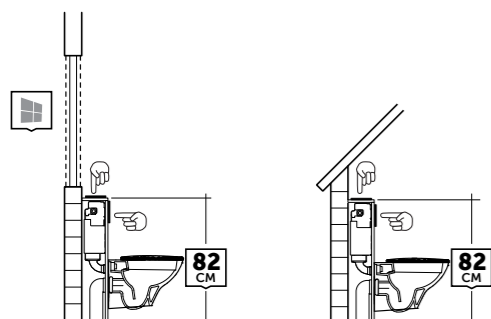

### Low-height situations

Altezze ridotte / Locaux bas / Niedrige Räumlichkeiten

Special element height 82 cm, with top or front flushing actuation.

Elemento speciale da 82cm, con placca frontale o dall'alto.

Élément spécial d'une hauteur de 82 cm, avec commande de chasse d'eau de devant ou d'en haut.

Spezialelement mit einer Höhe von 82 cm, mit Spülbetätigung von Vorne oder von oben.





# TECHNICAL INFORMATION 12 CM THICKNESS

Models | Modelli | Modèles | Modelle



Models | Modelli | Modèles | Modelle



12 CM FS12RAK12C

12 CM FS04RAK12C

12 CM Split Frame FS04RAK12A

12 CM FS09RAK1

Measurements | Misure | Dimensions | Abmessungen

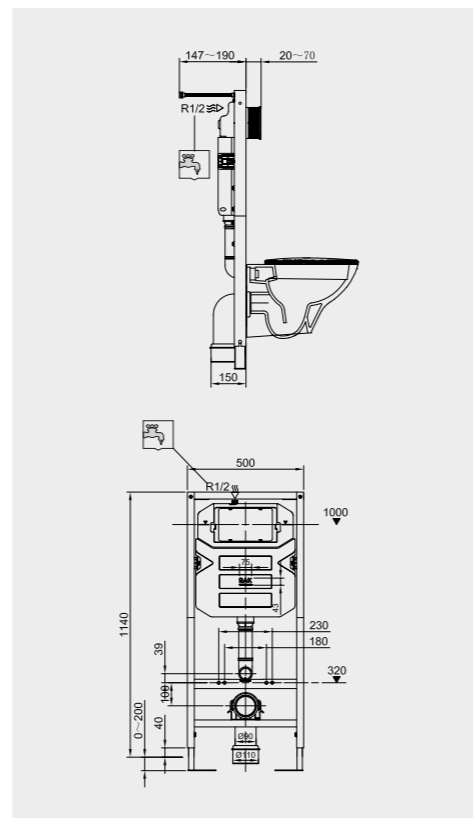
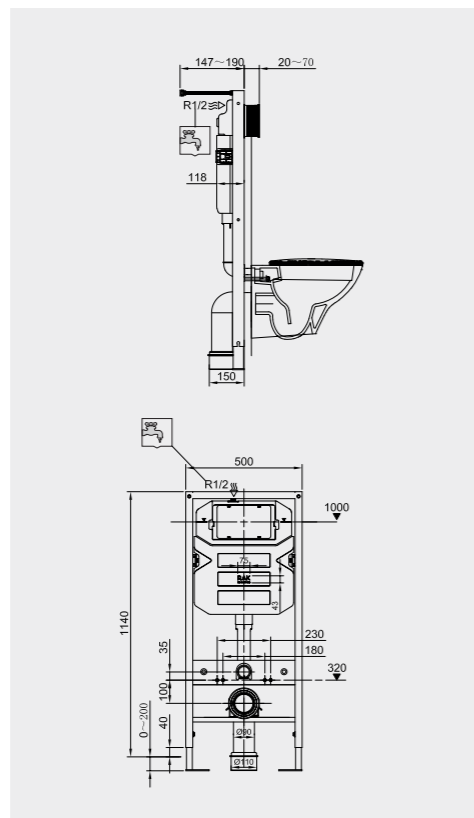
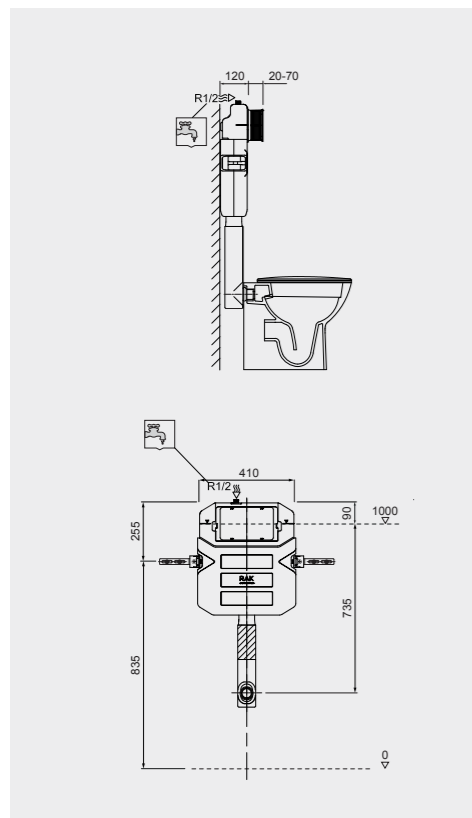

Measurements | Misure | Dimensions | Abmessungen

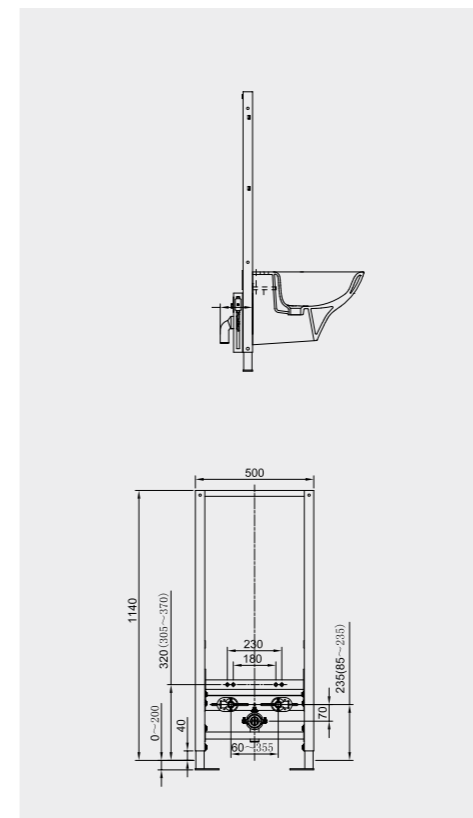

# TECHNICAL INFORMATION 8 CM THICKNESS

Models | Modelli | Modèles | Modelle



8 CM FS12RAK8C

8 CM FS05RAK8C

8 CM FS04RAK8C

Models | Modelli | Modèles | Modelle



8 CM FS09RAK1

Measurements | Misure | Dimensions | Abmessungen

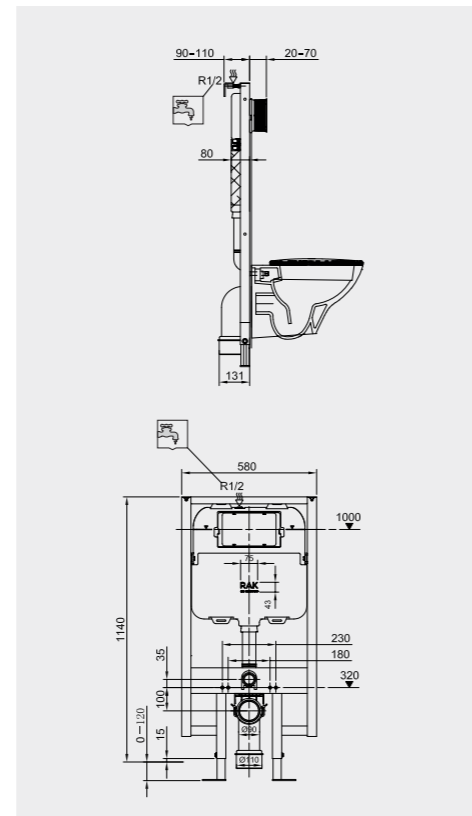
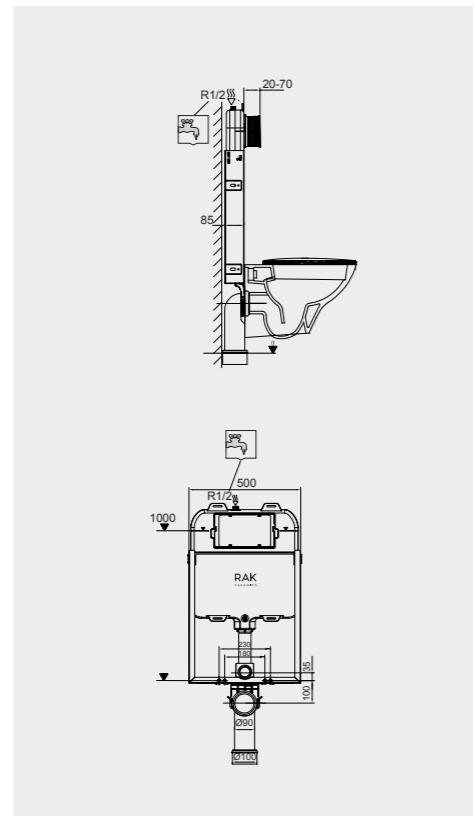
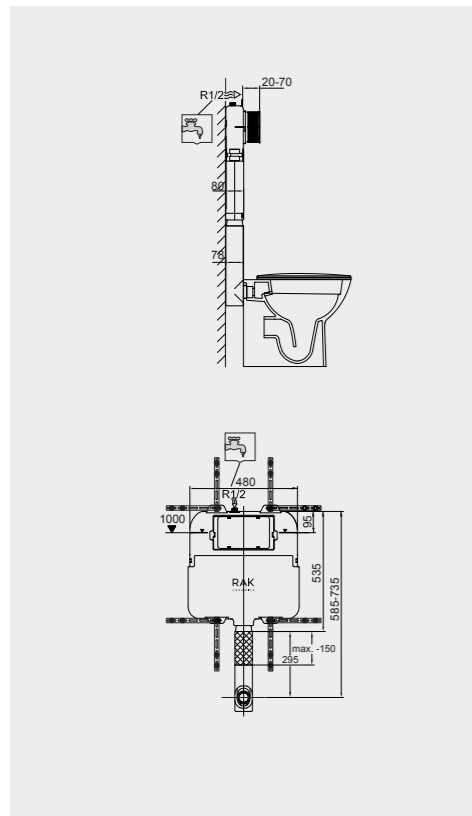

Measurements | Misure | Dimensions | Abmessungen

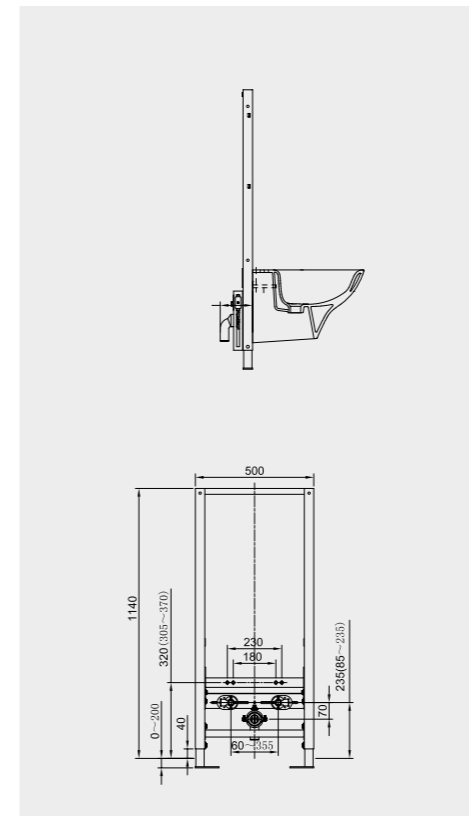

# TECHNICAL INFORMATION LOW HEIGHT

Models | Modelli | Modèles | Modelle



82 CM Front & Top Actuation  
FS12RAK82TF



82 CM Front & Top Actuation  
FS04RAK82TF



82 CM FS09RAK

Measurements | Misure | Dimensions | Abmessungen

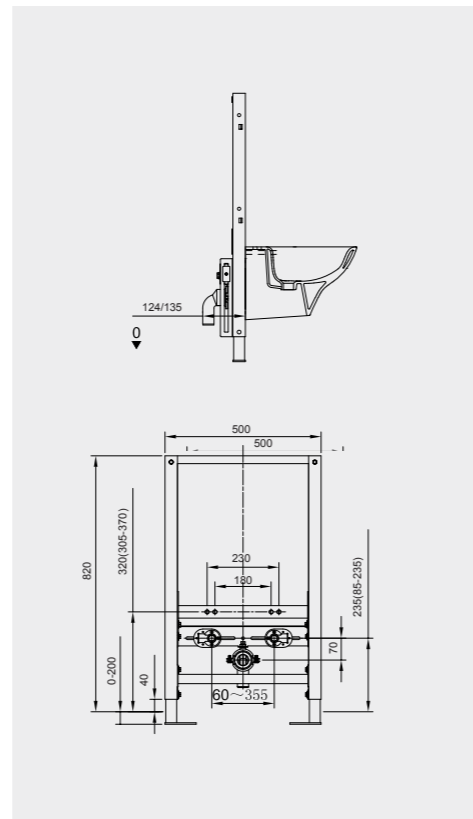
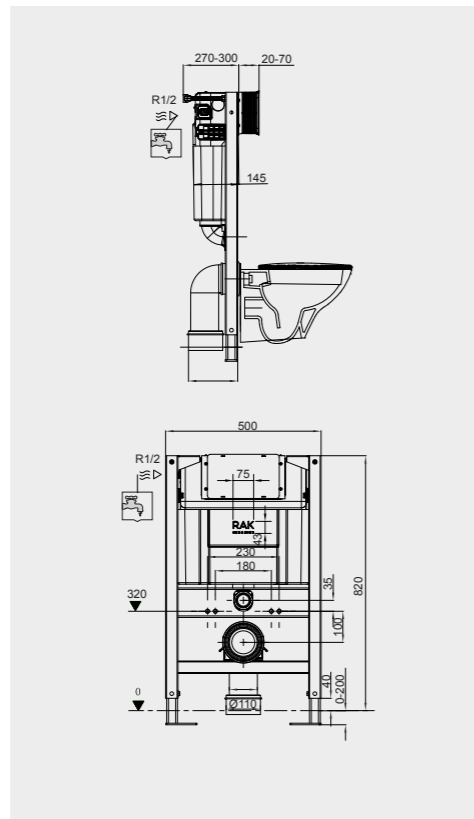
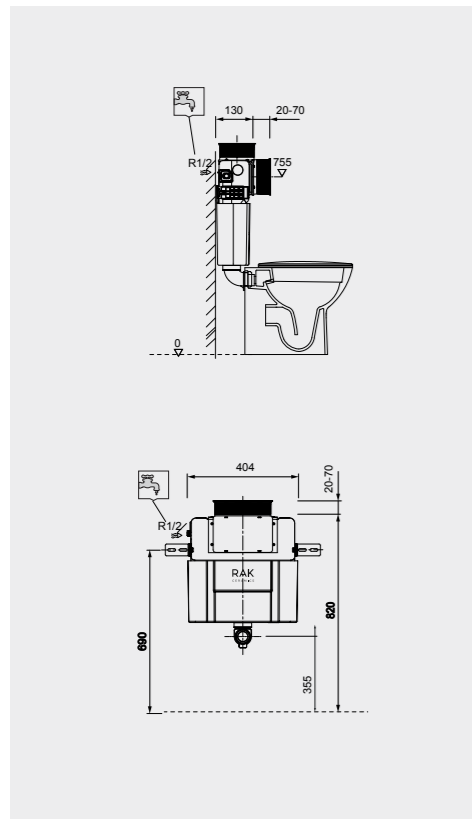

**CABINET CISTERNS**  
**CASSETTE ESTERNE**  
**RÉSERVOIRS DE CHASSE D'EAU DE CABINET**  
**SPÜLKÄSTEN FÜR KLOSETTS**



RAK-Ecofix cabinet cisterns are the sanitary modules for WCs with integrated cistern and refined additional functions. The perfect and stylish alternative to the front wall ceramic cistern. Suitable for Floor Standing or Wall Hung cabinet cisterns sanitaryware, RAK-Ecofix provides invisible technology but visible beauty.

Le cassette esterne Rak=Ecofix sono gli speciali moduli per WC con cassetta integrata. L'alternativa perfetta alla classica cassetta in ceramica. Disponibile per sanitari a parete o sospesi, Rak-Ecofix garantisce tecnologia invisibile ma qualità estetica visibile e ideale per ogni ambiente.

Les réservoirs de chasse d'eau de cabinet de RAK-Ecofix, objets sanitaires de toilette, aux réservoirs de chasse d'eau encastrés et avec des fonctions supplémentaires raffinées (??). L'alternative parfaite et stylistique aux réservoirs de chasse d'eau de mur, en céramique. Appropriés à la position posée ou suspendue, les réservoirs de chasse d'eau de RAK-Ecofix pour les objets sanitaires, offrent une technologie invisible qui s'unit à une beauté visible.

Die Klosettspülkästen RAK-Ecofix sanitäre Gegenstände für das WC, mit integrierten Spülkästen und raffinierten Zusatzfunktionen. Die perfekte und stilistische Alternative zu Wandspülkästen aus Keramik. Geeignet für die stehende oder hängende Position, bieten die Spülkästen RAK-Ecofix für sanitäre Gegenstände eine unsichtbare Technologie verbunden mit einer sichtbaren Schönheit.



**FOR WALL HUNG WC**  
 Per WC sospeso  
 Pour WC contre le mur  
 Für Wandhängendes WC



**Code: FS04RAKABBLK**  
 Flush technology: Dual flush  
 Dimensions: 100x48x11 cm



**Code: FS04RAKABWHT**  
 Flush technology: Dual flush  
 Dimensions: 100x48x11 cm



**FOR WALL HUNG BIDET**  
 Per bidet sospeso  
 Pour bidet suspendu au mur  
 Für Wandhängendes Bidet



**Code: FS04RAKAB02**  
 Dimensions: 100x48x11 cm



**Code: FS04RAKAB01**  
 Dimensions: 100x48x11 cm



**FOR BACK TO WALL WC**  
 Per WC a filo muro  
 Pour WC posé au sol  
 Für Rückwandmontage WC



**Code: FS12RAKABBLK**  
 Flush technology: Dual flush  
 Dimensions: 100x48x11 cm



**Code: FS12RAKABWHT**  
 Flush technology: Dual flush  
 Dimensions: 100x48x11 cm



**FOR BACK TO WALL BIDET**  
 Per bidet a filo muro  
 Pour bidet contre le mur  
 Für Rückwandmontage Bidet



**Code: FS12RAKAB02**  
 Dimensions: 100x48x11 cm



**Code: FS12RAKAB01**  
 Dimensions: 100x48x11 cm

Models | Modelli | Modèles | Modelle



White  
Bianca  
Blanc  
Weiß

**FS04RAKCABWHT**

Black  
Nero  
Noir  
Schwarz

**FS04RAKCABBLK**



White  
Bianca  
Blanc  
Weiß

**FS04RAKAB01**

Black  
Nero  
Noir  
Schwarz

**FS04RAKAB02**

Measurements | Misure | Dimensions | Abmessungen

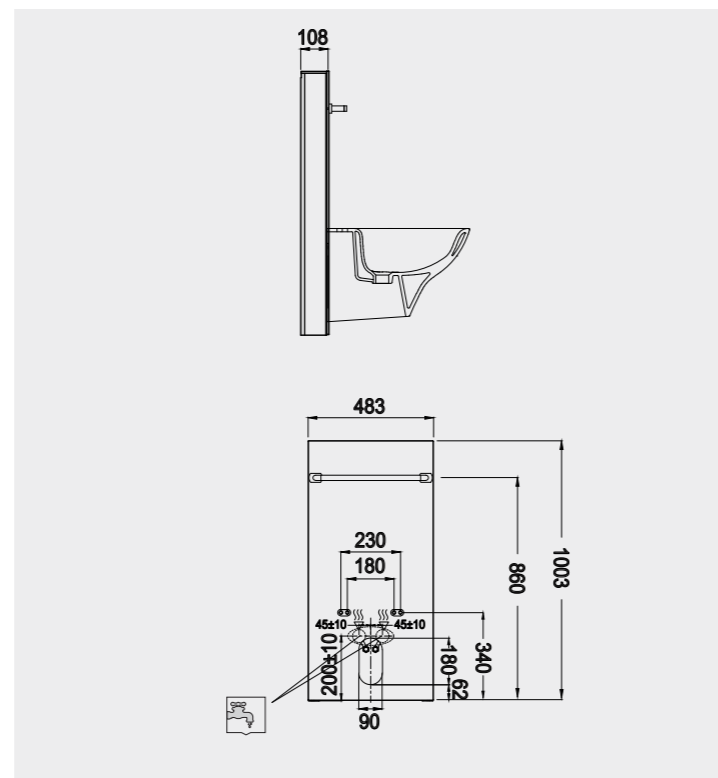
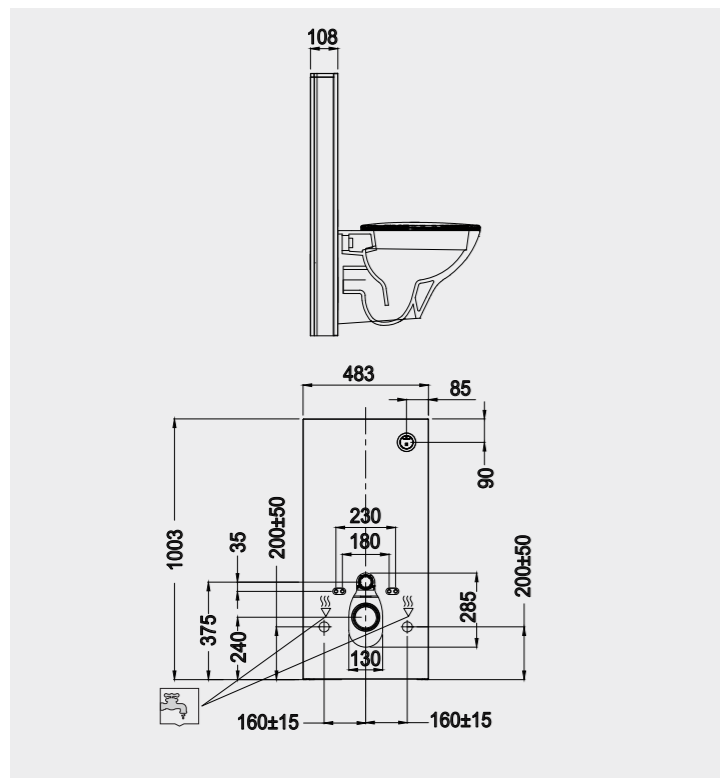

Models | Modelli | Modèles | Modelle



White  
Bianca  
Blanc  
Weiß

**FS12RAKCABWHT**

Black  
Nero  
Noir  
Schwarz

**FS12RAKCABBLK**



White  
Bianca  
Blanc  
Weiß

**FS12RAKAB01**

Black  
Nero  
Noir  
Schwarz

**FS12RAKAB02**

Measurements | Misure | Dimensions | Abmessungen

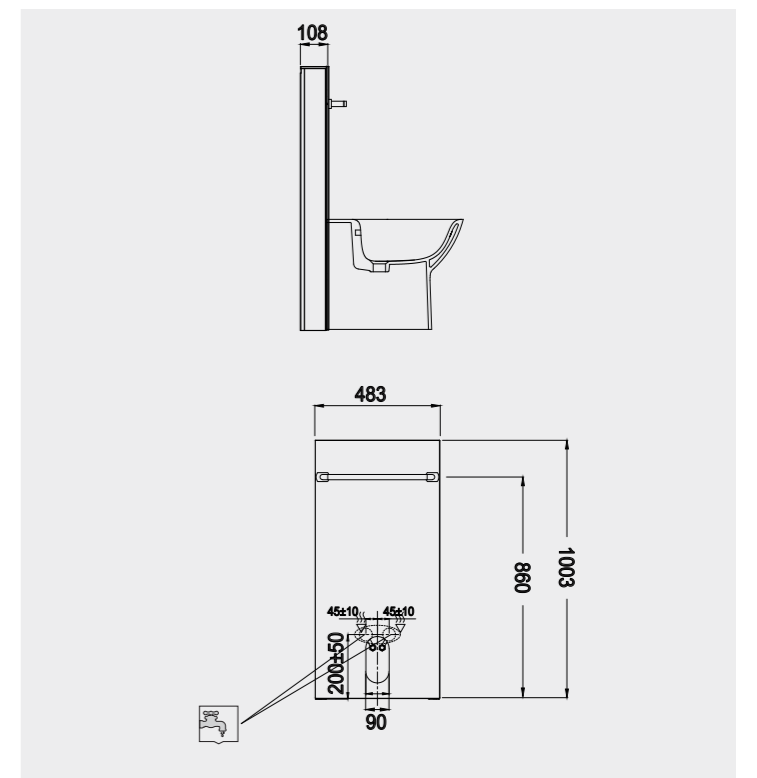
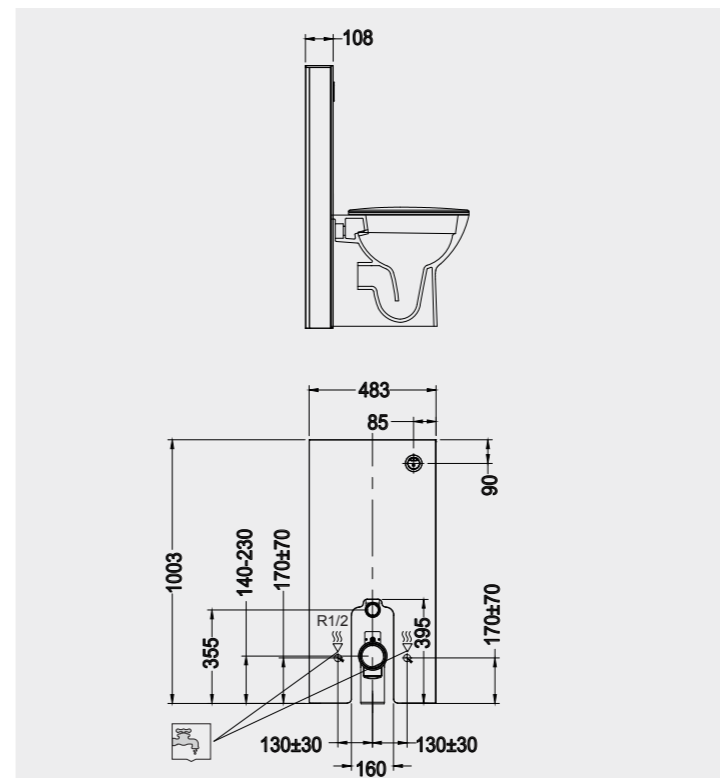

**FURNITURE CISTERNS & UNIVERSAL FRAME**  
 SISTEMI DI RISCIACQUO DA INCASSO PER MOBILI  
 RÉSERVOIRS DE CHASSE D'EAU POUR MEUBLES  
 SPÜLKÄSTEN FÜR MÖBEL



RAK-Ecofix low height concealed cisterns are designed to fit even the smallest furniture units on the market. The easy to fit cistern can be accessed for maintenance simply through the removable front panel of the furniture unit, or from the top via a removable shelf.

I sistemi di risciacquo ad altezza ridotta Rak-Ecofix sono progettati per essere installati persino nei più piccoli mobili da bagno disponibili sul mercato. La cassetta può essere facilmente ispezionata in caso di manutenzione attraverso il pannello frontale rimovibile o il ripiano superiore.

Les réservoirs de chasse d'eau bas de RAK-Ecofix sont conçus pour équiper même les plus petits meubles en vente. Le réservoir de chasse d'eau facile à encastrer, est facilement accessible aux travaux de maintenance, par le panneau de front démontable du meuble, ou d'en haut, par une case démontable.

Niedrige Einbauspülkästen von RAK-Ecofix sind dafür entworfen, selbst die kleinsten Möbelstücke auf dem Markt auszustatten. Der einfach einzubauende Spülkasten ist für Wartungsarbeiten einfach zugänglich, durch das abnehmbare Frontpaneel des Möbelstücks oder von oben, durch ein abnehmbares Fach.

Models | Modelli | Modèles | Modelle



Lateral Inlet  
FS12SRAKSI



Bottom Inlet  
FS12SRAKBI



FS04RAKC

Measurements | Misure | Dimensions | Abmessungen

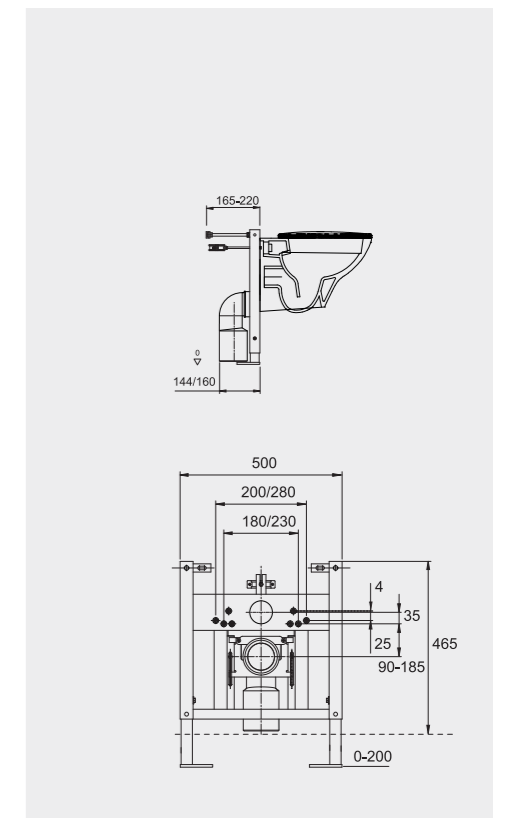
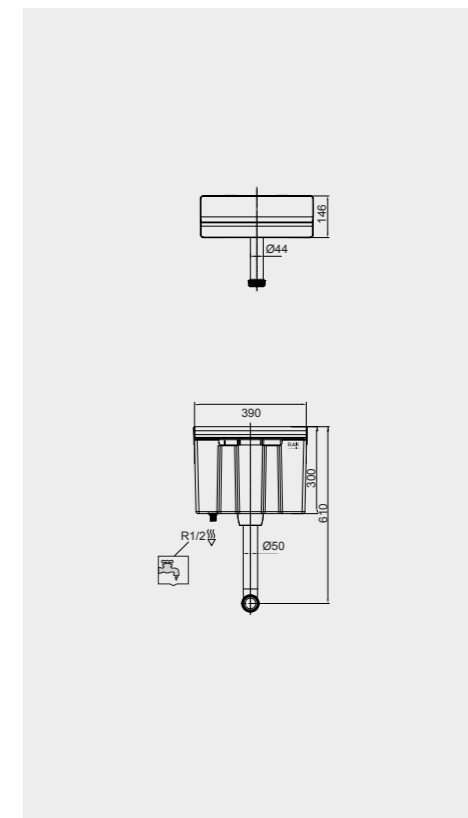
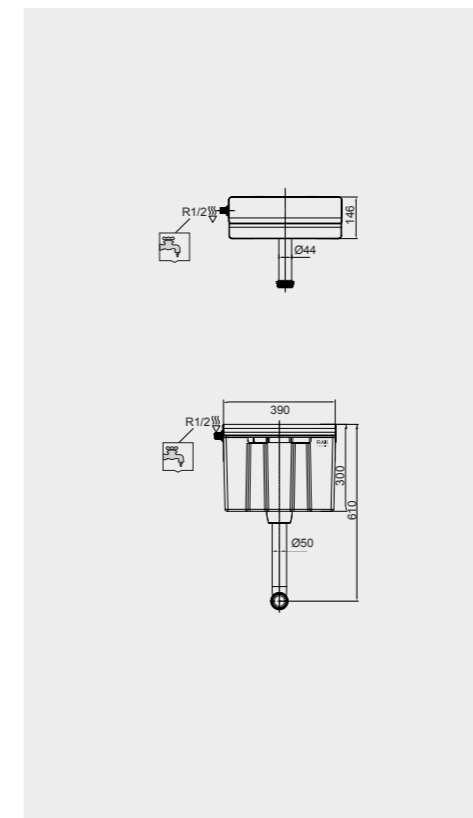

**URINAL FLUSH SENSORS**

SENSORI DI RISCIACQUO PER ORINATOI  
 CAPTEURS DE CHASSE D'EAU POUR LES PISSOIRS  
 SPÜLSENSOREN FÜR PISSOIRS



RAK-Ecofix range includes urinal electronic sensor system. The sensor automatically flushes the individual urinal after use, ensuring the highest level of hygiene from the minimum volume of water.

La gamma Rak-Ecofix comprende i sensori di risciacquo elettronici per orinatoio. I sensori consentono il risciacquo automatico dell'orinatoio dopo l'uso, garantendo il massimo livello di igiene ed il minimo consumo d'acqua.

La gamme de RAK-Ecofix comprend également un système de capteurs électronique pour les pissoirs. Le capteur rince le pissoir automatiquement, après l'usage, et garantit ainsi en même temps une hygiène maximale et une consommation d'eau minimale.

Die Palette von RAK-Ecofix umfasst ebenfalls ein elektronisches Sensorsystem für Pissoirs. Der Sensor spült das Pissoir automatisch nach dem Gebrauch, und gewährleistet somit ein Maximum an Hygiene bei minimalem Wasserverbrauch.

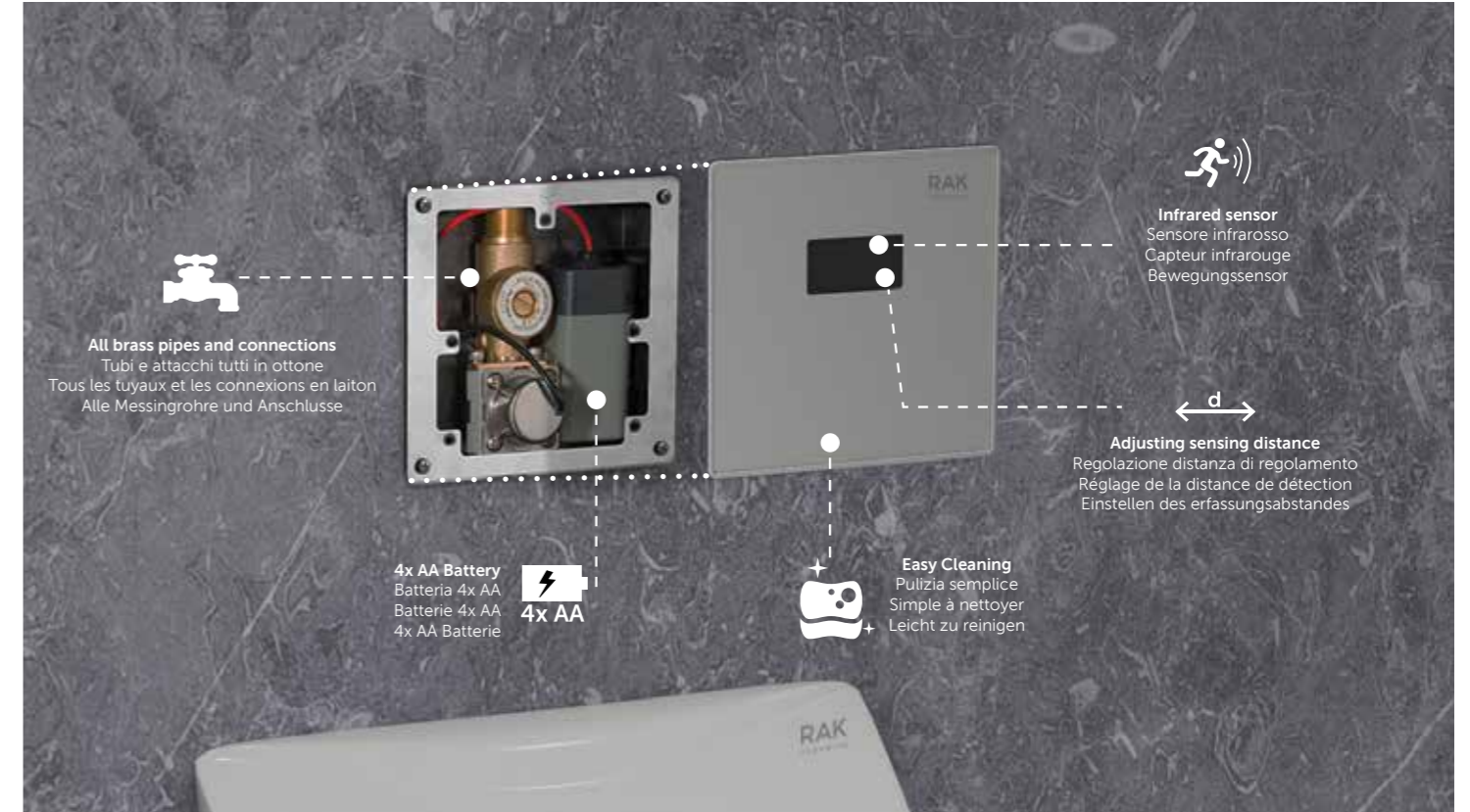

FS10RAK

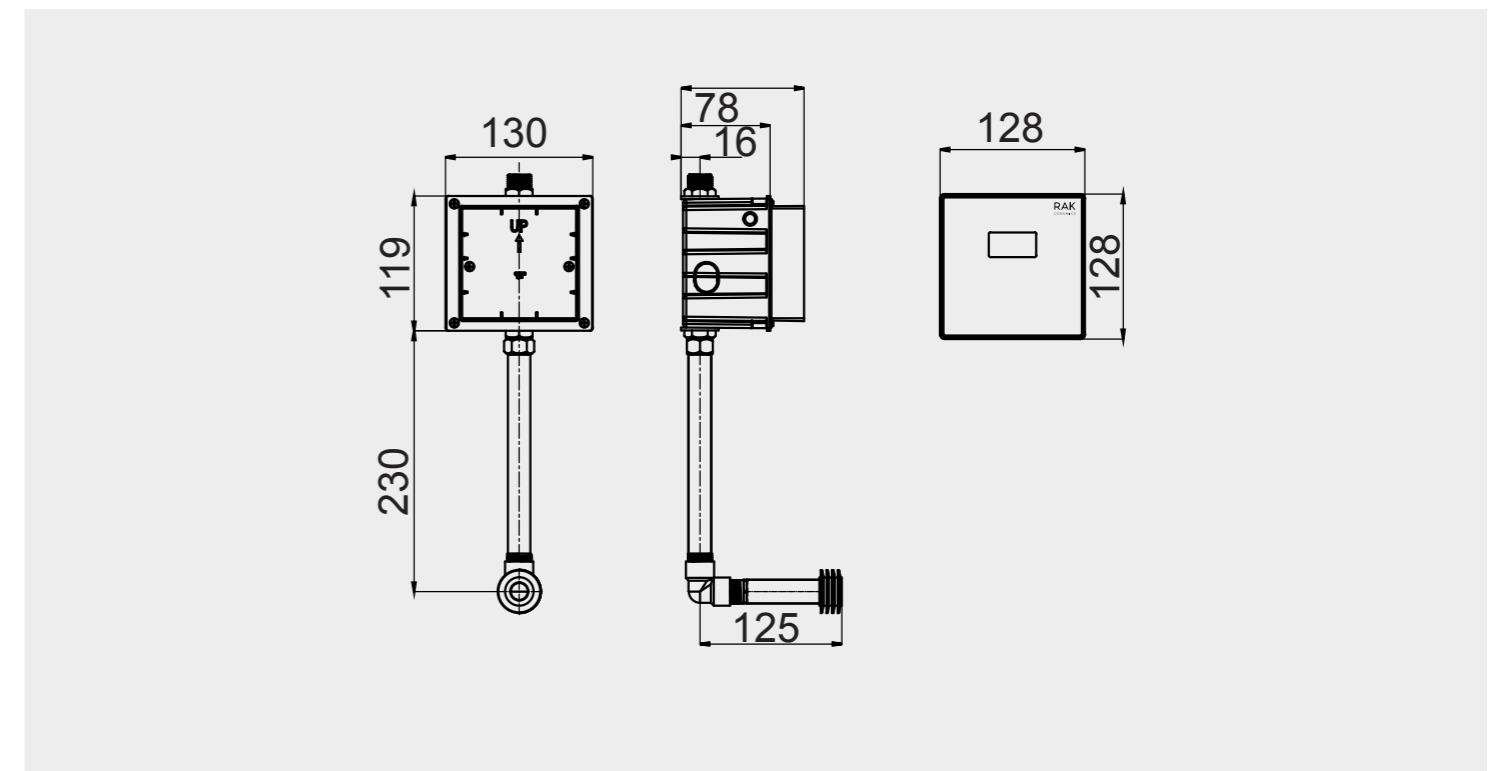

RAK CERAMICS  
P.O. Box 4714, Ras Al Khaimah,  
United Arab Emirates (U.A.E.)  
Tel.: +971 7 2467000  
Fax: +971 7 2445270  
Email : info@rakceramics.com

---

**RAKCERAMICS.COM**

---



[RAKCERAMICS.COM](http://RAKCERAMICS.COM)

**RAK**  
CERAMICS